

COMPACT EXCAVATOR

SWE25UF

Engine Power: **19.6 HP / 14.6 kW**

Machine Weight: **5,843.3 lbs / 2650 kg**



Reliable, Powerful and Durable

All key components are carefully selected

We chose the powerful Yanmar 3 TNV 80F engine for a number of good reasons. This engine uses indirect injection and it features low fuel consumption, low noise and vibration levels, and high-altitude performance control. This 19 hp (19.6HP) industrial diesel engine is both EPA Final Tier 4 and Stage V compliant, and its compact design means it can fulfill a variety of roles. The perfect fit for our reliable and versatile SWE 5UF.

Because the hydraulics are often regarded as the heart of the machine, Sunward sources exclusively from the highest references in the market. For our 2 new mini excavators, we selected Japanese premium brands to be our main suppliers for the hydraulic pump, traveling and swing motor. NACHI and Kayaba pumps and components are efficient, reliable, and space-saving. So, it's no coincidence that Sunward selected them to contribute to the SWE25UF's reliability.

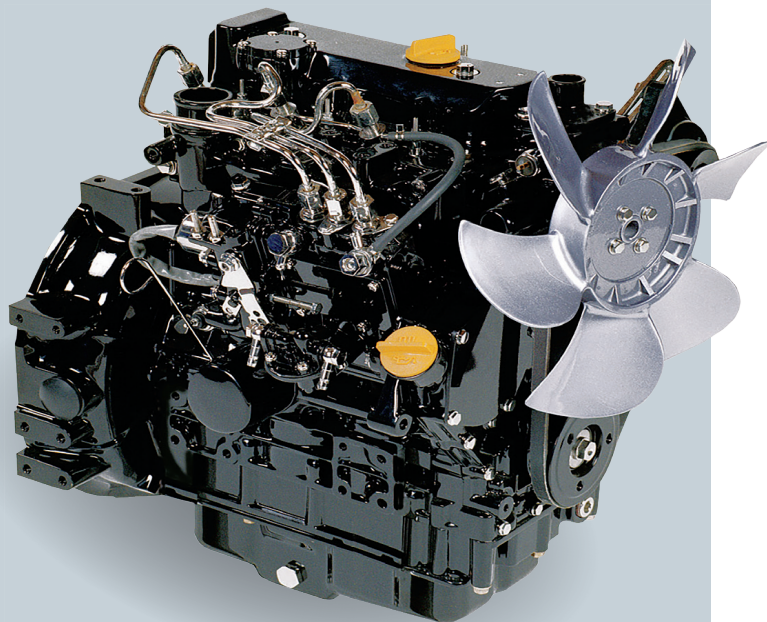

Premium brand critical components

YANMAR

Stage V engine

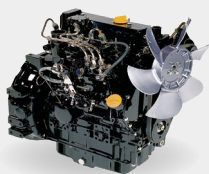

KYB/HENGLI

Cartridge
Valves and joystick

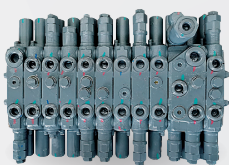

NACHI/HENGLI

Main pump

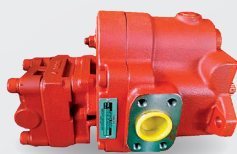

KYB/EATON

Traveling motor



NACHI

Swing motor

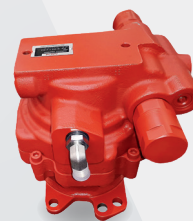

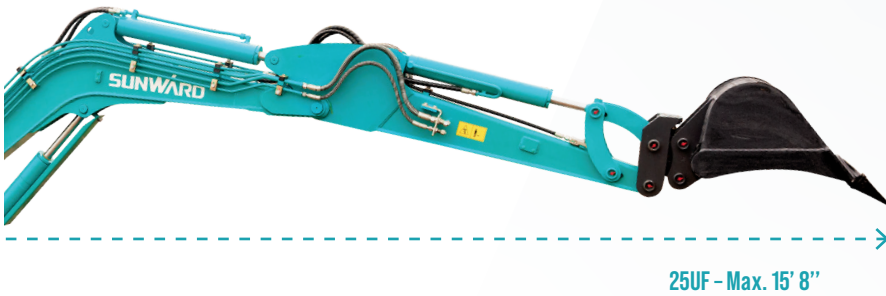

Best digging forces and long-reach capacity on the market

The SWE25UF has exceptional digging forces – 24 kN (bucket) and 14 kN (arm) – easily rivaling any 2.5t excavator competitors on the market. And when it comes to the long-reach capacity, the SWE25UF's boom cylinder provides a digging reach that's over 15' 8" (4.7 meters) long – making this compact excavator the benchmark of its range.

Protection plates for boom and dozer cylinders

When working in the field, an excavator's boom cylinders are particularly at risk of damage caused by flying stones. We've taken special care to protect the boom and dozer cylinders with covering plates, so that the operator can focus fully on his job and not worry about the machine's components. And when you rent your machine, you know it will come back in good shape, ready for many more hours on the job.



SMOOTH OPERATIONS THANKS TO

Auto gear shifting during traveling

If the SWE 25UF encounters an obstacle during high-speed traveling, the machines feature auto high & low speed gear shifting. To increase traction to get over the obstacle, the SWE25UF shifts from high speed to low speed automatically. And then, after getting over the obstacle, the machine automatically returns to high-speed mode. This automatic gear shifting frees the operator from having to frequently flip the 2-speed switch.

Pilot traveling control

To continually enhance precise and controlled operations, all of our 2.5t mini excavators provide pilot traveling control as a standard feature.

Versatile and Optimized

Engineering and design produce optimal, versatile machines

In the spirit of Sunward's motto – 'Innovation Leads to Value' – all engineering and design are focused on generating optimal value for the machine's owner. So, our machines can be used in a large variety of working conditions and applications – exactly what you're looking for in a 2.5t mini excavator.

Well-equipped from the outset

This slightly over 2.5t machine is very well equipped from the day it leaves the factory:

- Double Acting Hydraulic Circuit
- Factory-fitted Hydraulic Quick Hitch
- LinesFactory-fitted Hammer & Rotation Line
- Factory-fitted Case Drain Line
- Factory-fitted One hydraulic pilot control with double contact switch
- Factory-fitted Tiltrotator Configured Joystick Controls (tiltrotator of your choice – Engcon, Steelwrist or Rototilt)



Ready to face any situation from Day 1 on the job site



Full auxiliary lines as standard

Thanks to the complete auxiliary settings built in as standard, the SWE25UF provides fully adjustable pressure and flow monitoring for all types of attachments on any job site.

This results in no less than 3 separate auxiliary lines as standard (while the market provides 1 to 2 lines as standard), which are distributed as follows:

- 1 line at the bottom of the arm (AUX1), which is used primarily for the hydraulic quick-coupler
- 1 line for greater flow to fulfill the requirements of a flow-demanding attachment, such as a breaker (AUX2)
- 1 line with lesser flow as an extra line for attachments that are equipped with 2 actuators (AUX3)

Extra protection for hoses/AUX 2 lines



Ready for all kinds of jobs

The SWE25UF has full factory fitted equipment from Day 1, including all the features to welcome the most demanding attachment, i.e. the tiltrotator.

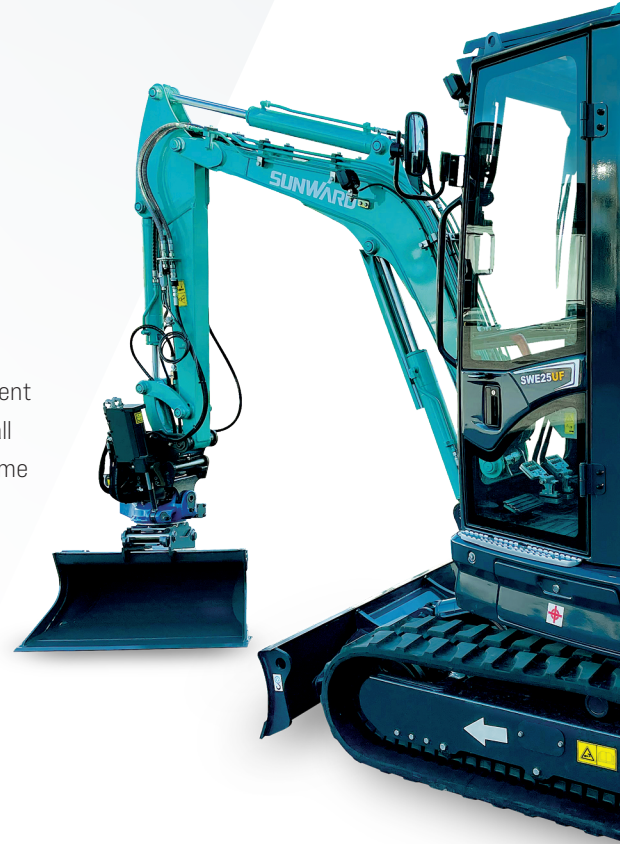

Compact for easy transport

A 2.5t compact excavator's versatility starts with how well it is designed for transportation. The SWE25UF does more than simply align with the transportation regulations – truly compact (4' 11" width) and lightweight (5843.3lbs), this machine allows easy, safe and secure transport. With automatic slew lock and 4 easily accessed tie-down points on the upper frame, the machine can be safely transported on a small trailer with up to 3 buckets and a hydraulic breaker.



Compact and neat – easy to transport to any job site

Safe and Comfortable

All Sunward machines on the market are designed to meet all customer needs. Without compromising comfort and safety.



Suspension seat

Simple interface

Safe & Comfy Cab

FOPS and TOPS cab tops are standard and among the first features to ensure a safe and comfortable job in all application environments.

The well-organized cab is clearly designed to keep operators comfortable and productive. The large entrance to the roomy cab welcomes all operators. From the suspension seat and heating, to the adjustable arm rest and the radio with USB ports, the cab's features promote efficiency. The superior visibility through the large windows, and the clear layout of the controls, add to the great ease of operation. Finally, the safety pack – including fire extinguisher, safety hammer, and safety belt – contributes to overall peace of mind.

Large windows
for full visibility and thus safe work



Simple
operation

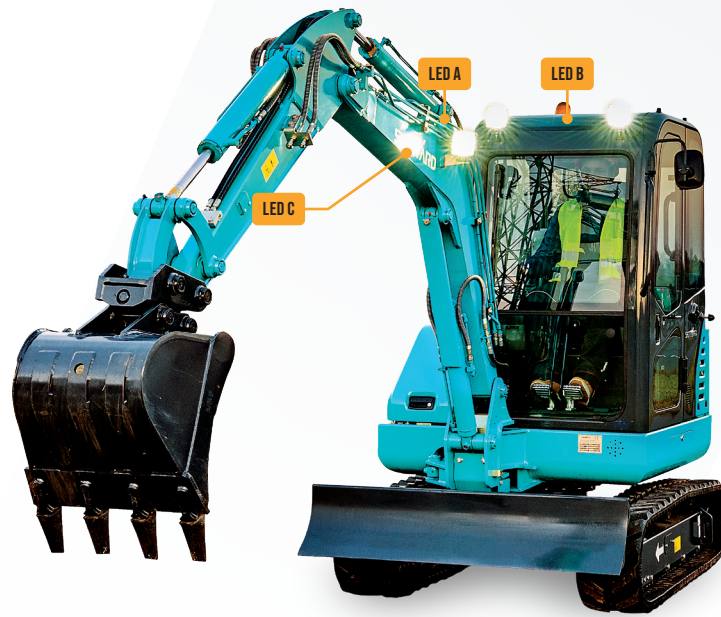

Extra rear visibility and safety as standard

All-around visibility on bright and grey days

The cab's wide windows and slender frame, enhanced by mirrors on both sides, make it easy to operate with all-around awareness of the machine's environment. Plus, to keep working conditions safe in all kinds of weather, 24 hours a day, these compact excavators are equipped with 3 LED work lights as standard: 2 on the front of the cab and 1 on the left side of the boom.



Color monitoring digital and analogue combined display

The easy-to-read 5.7" color monitoring digital and analogue combined display – with centralized functions and simple interface for easy operation – makes all key information readily accessible: machine status, engine rpm and temperature, fuel level, machine hours, oil indicators and charging indications.

Direct Support within America



Readily available machines & parts

Readily available machines & parts

From its Dallas headquarters, Sunward America can ensure rapid delivery of machines and spare parts everywhere in America. Machines can be delivered within a few weeks from local dealers, and Sunward machine operators benefit from quick and easy access to the large Dealers' Parts Warehouse (DPW) distribution center in Dallas.



SUNWARD GENUINE PARTS ARE BUILT, TESTED, AND PRODUCED TO PROVIDE OPTIMUM PERFORMANCE, DURABILITY, AND SAFETY.

Dealers all over America and Canada

Dealers are at the heart of Sunward's passion for continuous improvement. Our dealers' knowledge is a real asset – and because they serve local market needs, their feedback enhances our engineering and design innovations. Sunward's innovations create value – for machine operators and, ultimately, for our dealers.

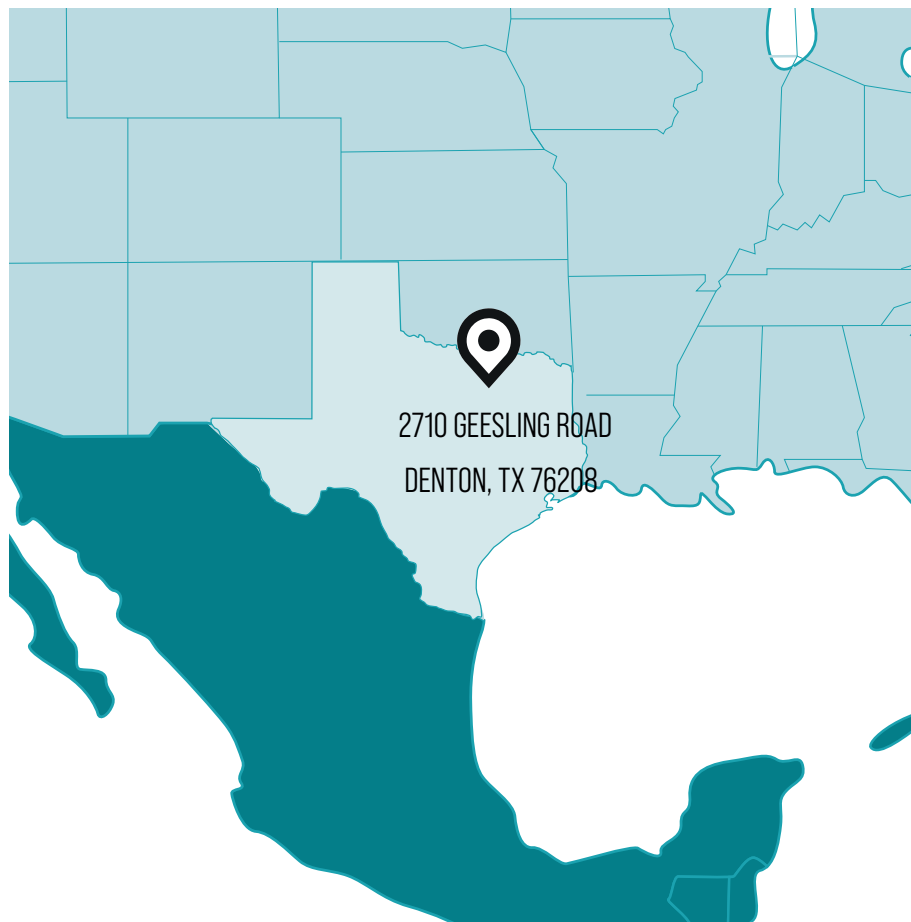

EQUIPMENT

The standard and optional equipment varies from country to country. For more information, please contact us.

		STANDARD EQUIPMENT	OPTIONAL EQUIPMENT
CAB	Digital and analogue combined display	•	
	AM/FM radio with usb port	•	
	Cup holder	•	
	Seat with shock absorber	•	
	Engine meso-position start system	•	
	Heater	•	
	Retractable harness	•	
	TOPS	•	
	FOPS	•	
	Windscreen washer and wiper	•	
	Rearview mirror	•	
	Cigarette lighter	•	
	Travel alarm	•	
	Right proportional joystick		•
	Dual proportional Joystick		•
FRONT WORKING DEVICES	11.81 in bucket		•
	21.65 in bucket		•
	47.24 in bucket		•
	53.15 in arm	•	
	Blade & Boom cylinder protection plate	•	
	Kit safety valve (Protections+Boom & Arm safety valve+Overload box+Ring on bucket link)		•
	Kit safety valve Blade		•
TRACKS	Breaker piping	•	
	11.81 in rubber track	•	
	11.81 in steel track		•
ENGINE	Oil filter	•	
	Fuel filter	•	
	Fuel-water separator	•	
	Air filter	•	
	Radiator	•	
	Alternator	•	
	Battery cut-off switch	•	
	Expansion tank	•	
	Electronic fuel pump	•	
	Muffler	•	
HYDRAULIC SYSTEM	Hydraulic pilot control	•	
	Parking-upon-swing brake	•	
	Parking-upon-traveling brake	•	
	Dual-speed traveling system	•	
	Auto-shift travel system	•	
	1st Auxiliary hydraulic breaker circuit line to arm end (2 pipes)	•	
	2nd Auxiliary hydraulic circuit line to arm end (2 pipes)	•	
	3rd hydraulic quick hitch line to arm end (2 pipes)	•	
	Oil return pipe (1 pipe)	•	
	Auto-lubrication system		•
Hydraulic QH line Safety kit		•	
LIGHTS	1 Boom LED working light	•	
	2 Front cab LED working lights	•	
	Warning beacon light for closed cab version	•	
	Warning beacon light for canopy version		•
	Rear LED working light		•
OTHERS	Additional counter weight		•
	Smart fleet system		•

TECHNICAL PARAMETERS

		Imperial	Metric
TYPE OF CAB		Cab/canopy	Cab/canopy
BUCKET CAPACITY		0.105 yd ³	0.08 m ³
BUCKET WIDTH, STD.		1'11"	580 mm
MACHINE WEIGHT		5843.3/5622.8 lbs	2 650/2 550 kg
DIMENSIONS	Overall dimension (L × W × H)	13'7"×4'11"×8'1"	4 140 × 1 500 × 2 455 mm
	Minimum ground clearance	12.09"	310 mm
ENGINE	Brand	YANMAR	YANMAR
	Model	3TNV80F-SPSU	3TNV80F-SPSU
	Emission rating	Tier 4 Final	Tier 4 Final
	Displacement	0.33 gal	1.267 L
	Output	19.6 /2400 HP/rpm	14.6/2400 kW/rpm
TRACK	Type	Rubber track/steel track	Rubber track/steel track
	Rubber shoe width	11.7 "	300 mm
UNDERCARRIAGE	Track length	6' 6"	1990 mm
	Length to center of rollers	5' 1"	1560 mm
	Length to center of track	3' 11"	1200 mm
	Traveling speed (High/Low)	2.55/1.43 mph	4.6/2.4 km/h
	Gradeability	30 deg	30 deg
SWING SPEED		9(rpm)	10 rpm
GROUND PRESSURE		3.64 psi	25.1 kpa
DOZER SIZE	Width	4' 11"	1500 mm
	Height	12.7 "	325 mm
	Lifting capacity (Height/Depth)	12'9"/12'5"=]]]]	330/320 mm
HYDRAULIC PUMPS	Type	2 variable plunger pumps, 1 gear pump	2 variable plunger pumps, 1 gear pump
	Displacement	2*7.6+5.1+1.7 gal/min	2*28.8+19.2+6.5 L/min
	Hydraulic pressure	2*3408.44+2755.76psi	2*21.5+18 MPa
SWING MOTOR		piston motor	piston motor
TRAVEL MOTOR		piston motor	piston motor
FUEL TANK CAPACITY		6.87 gal	26 L

DIMENSIONS

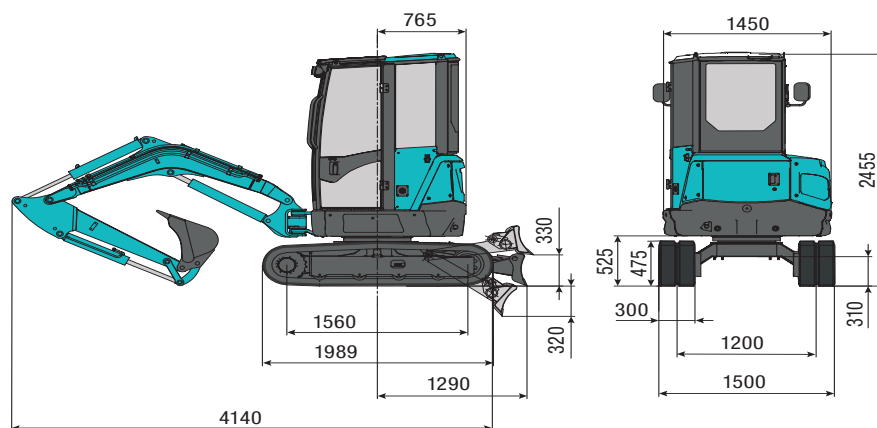

WORKING RANGE

WORKING RANGES		Imperial	Metric
	Max. cutting height	14' 3"	4 355 mm
	Max loading height	9' 10"	3 010 mm
	Max digging depth	9' 4"	2 840 mm
	Max vertical wall digging depth	8' 6"	2 580 mm
	Max digging reach	15' 8"	4 775 mm
	Boom swing angle (Left/Right)	65/50 deg	65/50°
	Front swing radius	6' 6"	1 980 mm
	Tail swing radius	2' 6"	765 mm
	Max digging force (Arm)	3,147.2 lbf	14 kN
	Max digging force (Bucket)	5,395.2 lbf	24 kN

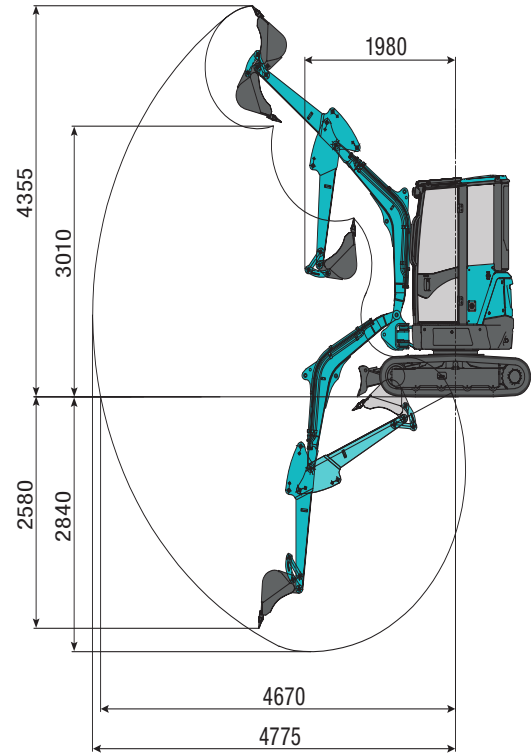

LIFTING CAPACITY

Lift Point Height (ft/m)	Lift Point radius (MAX)		Lift Point radius (9'10"/3.0 m)		Lift Point radius (6'7"/2.0 m)	
	Over-front (lbs/kg)	Over-side (lbs/kg)	Over-front (lbs/kg)	Over-side (lbs/kg)	Over-front (lbs/kg)	Over-side (lbs/kg)
9'10" /3.0	1266*/574.00*	878 /398.00	—	—	—	—
4'11"/1.5	1314*/596.00*	562 /255.00	1429*/648.00*	917 /416.00	—	—
0 /0	1343*/609.00*	538 /244.00	1899*/861.00*	761 /345.00	2800*/1270.00*	1314 /596.00
-3'3" /-1.0	1391*/631.00*	646 /293.00	1707*/774.00*	736 /334.00	2428*/1101.00*	1091 /495.00

Notes:

1. Load with * is limited by hydraulic capacity and based on ISO 10567. Rated loads do not exceed 87% of hydraulic capacity.
2. Load without * is limited by tipping load and based on ISO 10567. Rated loads do not exceed 75% of tipping capacity.
3. A: distance from center of rotation to perpendicular of weight; B: distance between bucket hinge pin and ground level.

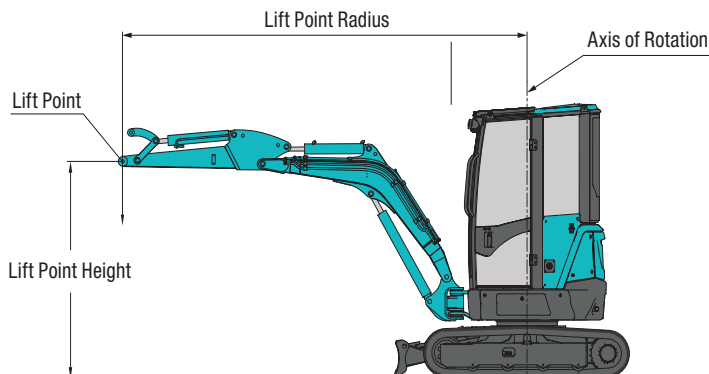

Sunward America and Sunward Canada

Please check our website for our current list of dealers.



SUNWARD AMERICA CORP

✉ 2710 Geesling Road
Denton, TX 76208

☎ (469) 353-6890

▶ Contact@sunwardamerica.com

🌐 www.sunwardamerica.com

DEALER CONTACTS