

MEDIUM EXCAVATOR

SWE215F

Engine Power: **172.9hp/129 kW**

Machine Weight: **48060lb/21 800 kg**



OFFERING THE BEST AVAILABLE

Presenting the SWE215F

With great pride, we introduce the **SWE215F medium excavator**. This top-of-the-line 21.8 t medium excavator offers excellent performance, comfortable and safe operation, and convenient maintenance. Versatile and durable, with a long lifetime, this machine is perfect for roads or buildings, quarrying, demolition or forestry.

The SWE215F's design, Tier 4 Final engine, and enhanced hydraulics system deliver smooth operation and increased productivity. A product of our company's innovative DNA, the SWE215F creates value for our customers and improves the quality of life.

In just 20 years, Sunward has grown to become one of the world's top 50 construction machinery manufacturers and top 20 excavator companies. Today, our products are exported to more than 100 countries worldwide.

Thank you for sharing our pride!

Professor He

Professor He

Main features

RELIABLE, POWERFUL AND DURABLE

We never compromise on reliability – and the 21.8 t SWE215F is no exception. We know it will be used by professional construction companies that are looking to get their work done with a durable machine they can trust. So, just like our other machines, all key components come from the world's top premium brands. From the Cummins Stage V engine to the Japanese-made hydraulic system, all is set for reliability and durability. Moreover, Sunward's unique hydraulic system enhances this machine's performance by providing one of the most powerful bucket break-outs on the market.

VERSATILE AND OPTIMIZED

Because a 22t machine is essentially a multiple large job site machine, it must be versatile. The SWE 215F has 3 major working modes and 3 extra working modes for the attachments – making this machine's versatility second to none. So, Sunward provides the highest flexibility on the market as standard, accommodating any working requirement and tool (including Tilt rotators).

SAFE AND COMFORTABLE

Because we know that safety and comfort should go hand-in-hand, the SWE215F keeps you safe and provides every comfort in all working conditions. The cab features FOPS and ROPS requirements, from the reinforced undercarriage to the reinforced frames for the boom and arm. And thanks to the full visibility provided by 3 powerful and perfectly positioned LED lights as a standard feature, you stay safe, day and night.

EASY TO MAINTAIN AND SERVICE

All Sunward machines are designed, prototyped and then disassembled - in the spirit of reverse engineering – simply to test how easy they are to be serviced and maintained. And they are! From ground-level access to service components, to the availability of parts – maintaining the SWE215F is easy and simple. So, it's no surprise that an operator only needs to try out our machines to be thoroughly convinced!

DIGGING FORCE – AND SO MUCH MORE



Reliable, Powerful and Durable

All key components are carefully selected

For example, we selected the award-winning Teir 4 Final Cummins B6.7 engine in its latest version. This engine sets the industry standard for reliability and durability. Its increased fuel economy and longer maintenance intervals contribute to lower cost of operation and lower Total Cost of Ownership. With near-zero emission levels, it delivers from 158 hp to 330 hp (116–243 kW) without compromising power, performance, or fuel economy.

As the hydraulics are often regarded as the heart of the machine, Sunward sources exclusively from the highest references in the market. For the SWE215F, we selected Japanese premium brands KPM for the hydraulic pump and swing motor and KYB for the Main Control Valve (MCV). Both highly reliable brands are known for their high efficiency and long-life components, designed specifically to meet the demands of hydraulic excavators.

To provide the best value to the user, we apply our 'Innovation Leads to Value' motto to every element of the machine – even to externally sourced components and the way we integrate them.

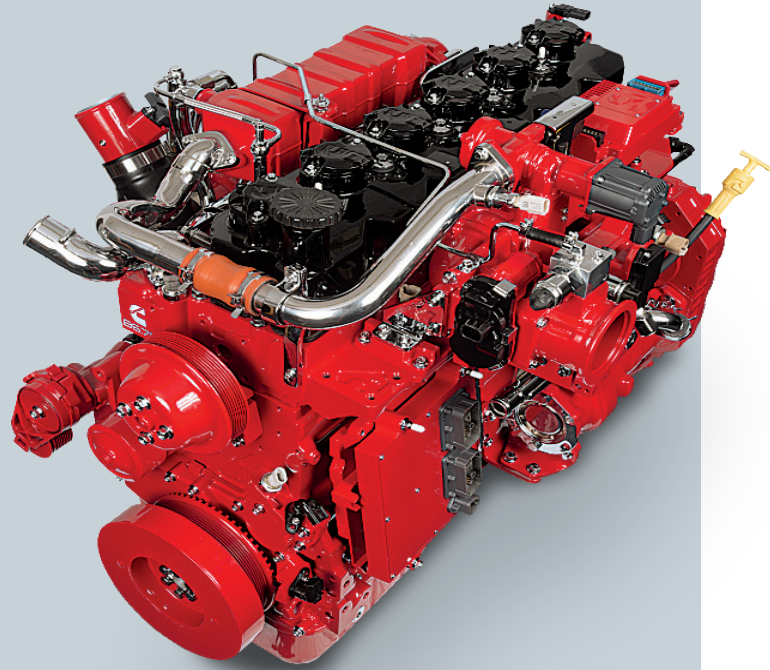

Premium brand critical components

KPM

Main Pump

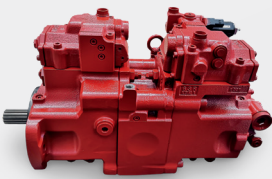

With this new premium-quality pump, and our innovative thinking, we increased the machine's displacement by 7%, power by 4%, and volume efficiency by 6% – making the entire excavator more energy-efficient.

KYB

Main Control Valve (MCV)

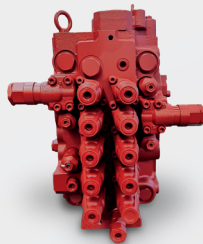

A large port size MCV provides more flow capability and less flow resistance – generating less heat and energy consumption, while still allowing a faster working speed. Our professional and dedicated calibration provides the operator with a better operating experience.

KPM

Swing Drive Motor

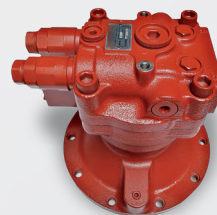

Our large displacement and big torque motor features multiple functions, such as self-lock, anti-rebounding, and hydraulic and mechanical duplicate brake system to ensure smooth operations.

NABTESCO

Traveling motor

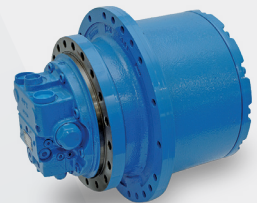

Each track is driven by a 2-speed automatic shifting travel motor, equipped with multiple discs and spring-locked and hydraulic-released brake. The unchallengeable traveling speed can reach up to 3.2 mi/h.

Strengthened boom & arm

Finite Element Analysis has been used to calculate the best load distribution throughout the boom structure. Also, the key parts of the SWE215F, such as the boom and the arm, are designed with an increased sheet material thickness with all supporting elements being made of high-strength, high-ductility and structural steel die-forged pieces. This analysis, combined with thicker material, means that element fatigue is limited and both reliability and component life are increased. To better protect the base of the arm, reinforced bars have been added and both the arm's center and end have been strengthened.

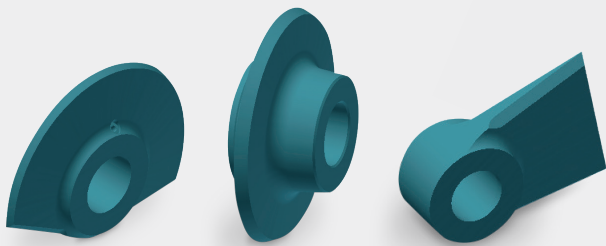

Forged supporting elements

STRESS RELIEF PROCESS FOR STRENGTH AND DURABILITY

The SWE215F is meant to handle normal construction work as well as it handles the heavy-duty work. That is why it's important to integrate that requirement in the initial stage of the machine's production. The SWE215F's heavy-duty implements are delicately annealed, which eliminates the residue stress in weld seams and increases the machine's reliability significantly.

THE ANNEALING PROCESS

After welding, the natural cooling process (with the risk of uneven cooling) is prevented by heating the metal in an isolated chamber to 1,112-1,472 °F and then cooled down slowly. This controlled cooling process – which usually takes 5-8 hours – permeates the texture of the steel with much better uniformity and compactness, while avoiding residual stress and defects. Therefore, it increases the durability of the machine. This kind of cooling process is usually not adopted by manufacturers who want to save time and money. But at Sunward, we do not compromise on quality – we strive to provide machines of the highest reliability and durability.

REINFORCED X CHASSIS WITH EXCELLENT RESISTANCE TO DISTORTION

Designed using Finite Element Analysis and 3D computer simulation, the X-shaped undercarriage ensures optimum structural integrity and durability.

From design to manufacturing process, all is done for reliable heavy-duty performance

In your work, you need equipment you can rely on. At Sunward, we use highly specialized design and analysis tools to make sure our machines are as robust and durable as can be. Our materials and structures undergo stringent testing for strength and resilience under the most extreme conditions. We constantly manufacture the most durable machines to ensure the lowest cost of ownership possible.

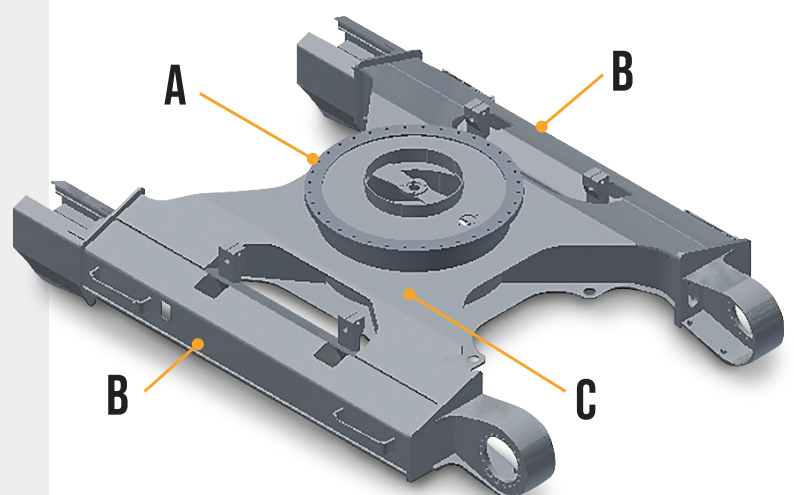
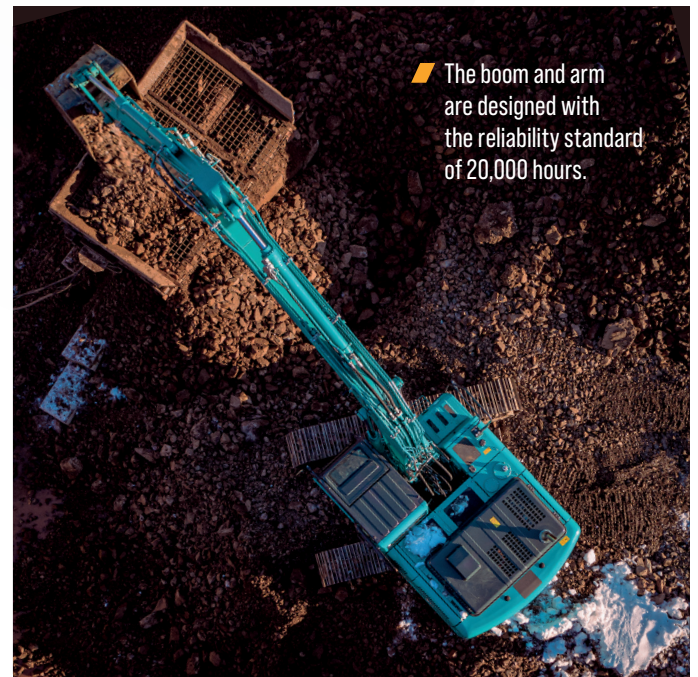

- A. The seat of the slew bearing is made of one ring-forged piece to reduce welding.
- B. A track frame with a larger cross-sectional side box and a thickened bottom plate are used to improve the overall strength.
- C. Both the cross-section area of the X-shaped frame and the plate thickness are increased to improve the overall strength.

Versatile and Optimized

Designed for versatility

In the spirit of Sunward's motto - 'Innovation Leads to Value' - the design and engineering of the SWE215F is focused on generating optimal value for the machine's owner, while offering optimum versatility to the machine's operator. The SWE215F can be used in a large variety of working conditions and applications. And thanks to the 3 separate auxiliary lines, the 3 bucket working modes, and the 3 attachment work modes, an operator needs only a few minutes to fully appreciate the possibilities offered.

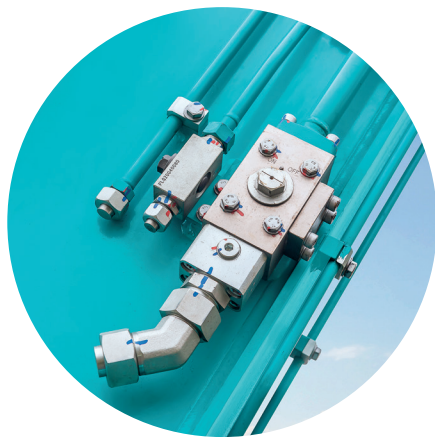

 AUX 2 lines

The highest auxiliary lines standard set-up available on the market

The SWE 215F can adapt to any job site, thanks to the complete auxiliary settings that are built-in as standard - providing fully adjustable pressure and flow monitoring for all types of attachments, including a tilt rotator.

This results in no less than 3 separate auxiliary lines as standard (while the market provides 1 or 2 lines as standard), which are distributed as follows:

- 1 line at the boom of the arm (AUX1), which

- is used primarily for the hydraulic quick-coupler
- 1 line for greater flow to fulfill the requirements of a flow-demanding attachment, such as a breaker (AUX2)
- 1 line with lesser flow as an extra line for attachments that are equipped with 2 actuators (AUX3)

2 of these auxiliary lines are equipped with a shut-off valve, making the attachment installation easy and oil leakage-free.

THE SWE 215F IS SYNONYMOUS WITH EASY CONNECTION AND EASY OPERATION.

The machine accepts several attachments to perform all desired jobs.

3 attachment work modes

Operators enjoy both versatility and fuel consumption optimization thanks to each dedicated mode:

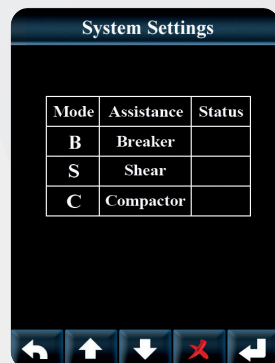

B
HYDRAULIC
BREAKER

S
HYDRAULIC
SHEAR JAWS

C
HYDRAULIC
COMPACTOR

By controlling 2 pumps independently, the SWE 215F optimizes attachments for effective flow rate setting, enabling various operations and matching the site's environment. You set the auxiliary circuit flow for each attachment work mode on the simple and clear monitor screen. So, you don't need to adjust the flow mechanically.

Designed for optimization

The Hyperbolic Curve and super Wear-Resistant New Style Bucket provides incredible operating efficiency. Both bottom and side plates of the bucket are made of high-strength wear-resistant steels from a premium brand, which makes the machine suitable for highly abrasive jobs. With this innovative design, the digging resistance is reduced significantly. So, digging is much smoother, and fuel consumption is significantly lower.

COMPARISON OF BUCKET DIGGING TRAJECTORIES

Simple curve design

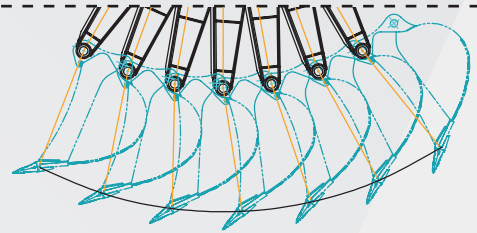

Hyperbolic curve Sunward optimized design

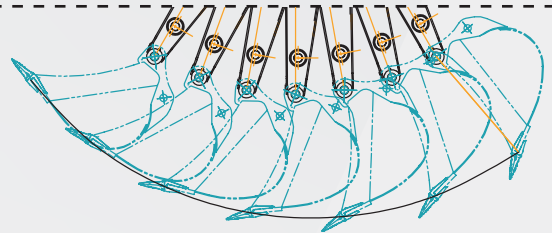

Best digging force even in heavy mode

Best digging force in the market

The SWE215F's low 340-bar pressure generates the highest digging force – 34,845.4 lbf – in the market. Sunward's machine also has the highest hydraulic efficiency, which results in low fuel consumption. Remember: with Sunward, Innovation Leads to Value!

3 bucket working modes

The operator can choose the proper working mode for different kinds of jobs:

LIGHT MODE

for light-duty jobs – to get the machine fine controlled.

STANDARD MODE

to get the job done with greater fuel-efficiency – optimizes performance and fuel efficiency of the equipment for general load work.

HEAVY MODE

for hard digging or to get the job done more efficiently – maximizes speed and power of the equipment for heavy load work.



3 auxiliary lines as standard make working with tilt rotators easy

Safe and Comfortable

All Sunward machines on the market are designed to meet customer needs. And that includes not compromising between comfort and safety.



Robust undercarriage for stability

The large undercarriage provides robust stability enhanced by 8 lower rollers and 1 top roller. This concept ensures safety, comfort, and maintainability.

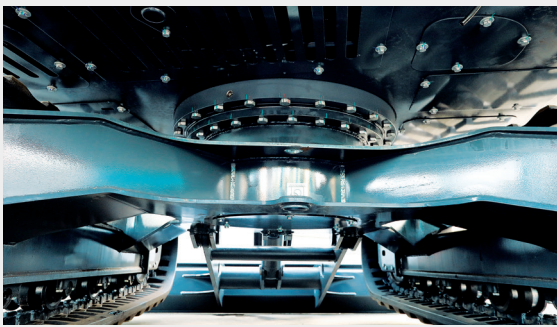

Engine STOP protection for extra safety

The SWE215F's engine protection system helps prevent progressive engine damage by proactively warning the operator of potentially damaging engine conditions and then by derating or shutting down. Sunward's engine start & stop protection technology reduces engine wear due to improper operation, prolonging the engine's service life.



Diesel Oil	Attention	Fuel and Lubricant Chart
Attention	Safety	
Attention		

Simple interface

Large windows
for full visibility and thus safe work

Fully equipped & spacious cab

The high-strength SWE215F cab meets FOPS and ROPS requirements, which are standard and among the first features to ensure a safe and comfortable job in all application environments.

To accommodate tall operators, the cab is easy to climb in and out of; and its roomy interior provides a comfortable and efficient work environment.

The SWE215F is designed to keep operators comfortable, productive, and absolutely safe. The fully adjustable air suspension seat – with easy access to several storage compartments – is standard. The air conditioning system has larger vents and regulates the interior temperature automatically for a better cooling or heating experience. The adjustable arm rest and the radio with USB ports allow you to work steadily without feeling tired.

Finally, the safety pack – including fire extinguisher, safety hammer, and safety belt – contributes to total peace of mind.

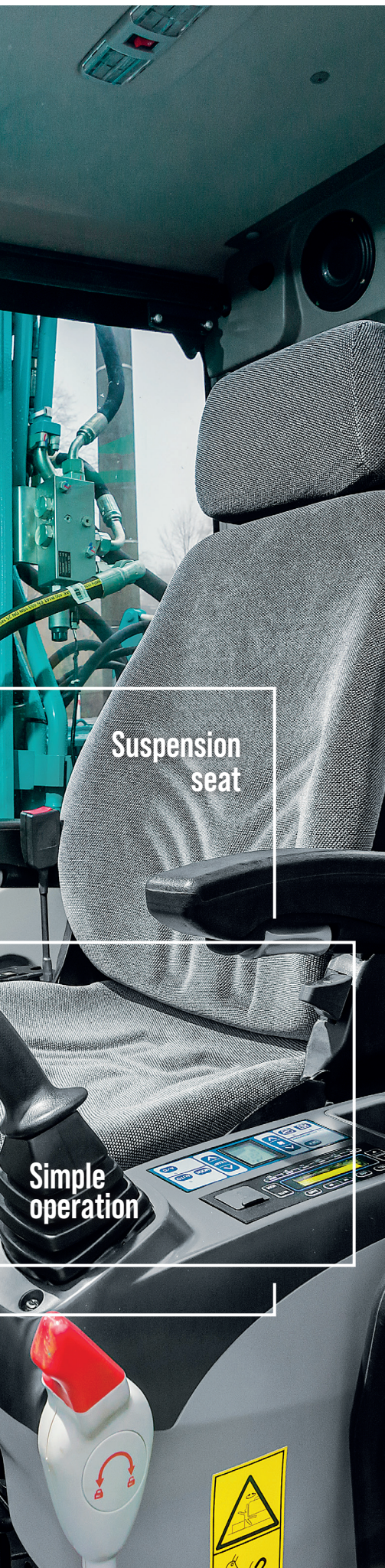

Suspension seat

Simple operation



Large-angle view and wide roof-top window facilitate all standard and elevated works

Rear camera: our standard features are options to others.

360° view and color monitoring screen

The latest standard equipment is the rear camera – which complements the large windows and glass rooftop to provide a 360° view. The easy-to-read 5.7" color monitoring screen – with centralized functions and simple interface for easy operation – makes all key information readily accessible: machine status, engine rpm and temperature, coolant temperature, fuel level, error codes, throttle gear, menu and switches and loading counter. So, the SWE215F promotes working safely and efficiently, without stress.

Easy Maintenance and Service

Centralized service points

The SWE215F is as easy to maintain as it is to operate. To reduce maintenance time and cost, the covers on the side and the top provide direct access to the service points. With extremely easy access to the fuel tank and centralized grease fittings, we even added handrails to make it easier to get around the machine.

01 ENGINE COMPARTMENT

Easy and quick check and refill of the engine oil level



02 RADIATOR & AIR FILTER COMPARTMENT

Easy check of the Coolant Expansion and Windshield Washer Tank



03 HYDRAULIC PUMP COMPARTMENT

Easy check and replacement of oil filter, fuel filter, fuel/water separator, and pilot filter



04 DEF DOSING SYSTEM

Well protected and easy access for maintenance



Did you know?

Operators and maintenance teams can enjoy a machine that has been designed, prototyped and then disassembled – in the spirit of reverse engineering – to facilitate all service and maintenance operations.

05 INTEGRATED GREASE FITTINGS

For almost zero maintenance routine

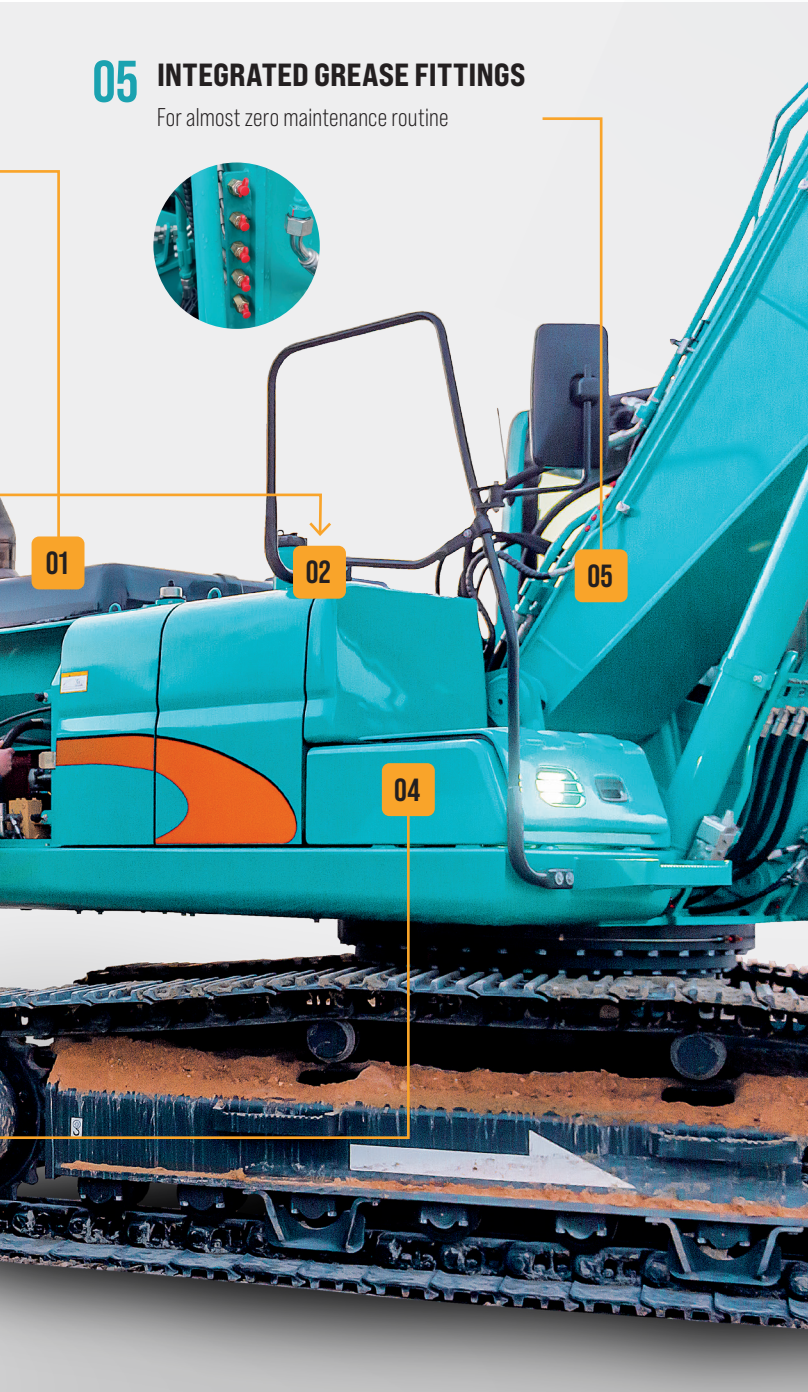

UP TO
3 YEARS
 OF WARRANTY
 + 2 YEARS
 EXTENDED WARRANTY
(available for additional cost)

Best Value for Money from A to Z

The SWE215F's expert design includes a well-thought-out selection of components that streamline operation and maintenance. Our design choices result in a machine that provides so many standard features, premium-brand key components, and capabilities at the right price. And furthermore, Sunward's own genuine spare parts are economical as well – and all of this best value for money is crowned by a 3-year standard warranty.

Direct Support within America



Readily available machines & parts

Readily available machines & parts from our Dallas headquarters, Sunward America can ensure rapid delivery of machines and spare parts everywhere in America. Machines can be delivered within a few weeks from local dealers, and Sunward machine operators benefit from quick and easy access to the large Dealers' Parts Warehouse (DPW) distribution center in Dallas.



SUNWARD GENUINE PARTS ARE BUILT, TESTED, AND PRODUCED TO PROVIDE OPTIMUM PERFORMANCE, DURABILITY, AND SAFETY.

Dealers all over America

Dealers are at the heart of Sunward's passion for continuous improvement. Our dealers' knowledge is a real asset – and because they serve local market needs, their feedback enhances our engineering and design innovations. Sunward's innovations create value – for machine operators and, ultimately, for our dealers.

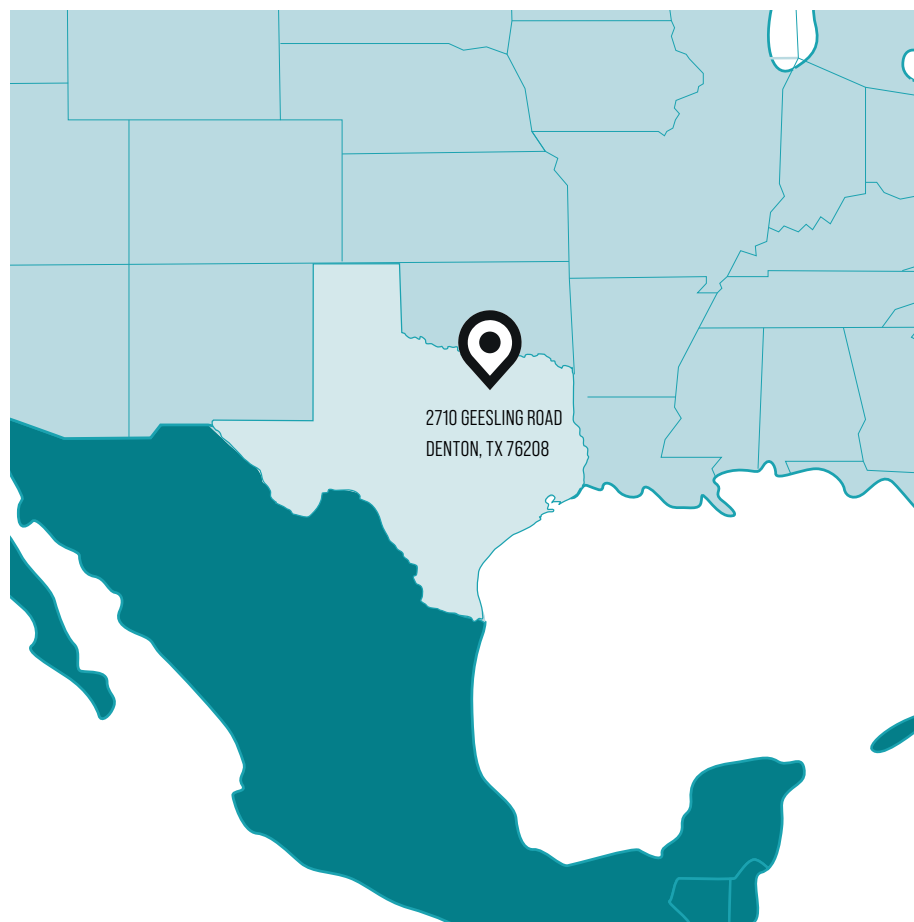

2710 GEESLING ROAD
DENTON, TX 76208

EQUIPMENT

The standard and optional equipment varies from country to country. For more information, please contact us.

		STANDARD EQUIPMENT	OPTIONAL EQUIPMENT			STANDARD EQUIPMENT	OPTIONAL EQUIPMENT
ENGINE	Turbocharging, 4-stroke, water-cooling, direct injection, diesel engine	•		CAB AND INTERNAL DEVICES	TOPS / FOPS / ROPS cab	•	
	Air filter with indicator	•			Spring aided silicone oil shock absorber	•	
	Multi-stage fuel filtering system	•			Radio (equipped with MP3 player and USB interface)	•	
	Emergency engine shutdown device	•			All-weather soundproof cab	•	
	Oil filtering system	•			RH+LH Hydraulic Joystick with electronic proportional thumb control switch	•	
	Cooling unit easy to clean	•			Multi-directional adjustable seat	•	
HYDRAULIC SYSTEM	Automatic pressure-boosting hydraulic system	•			Fire extinguisher	•	
	Boom and arm regeneration valve	•			Safety hammer	•	
	Swing relief & cushion valve	•			Cup holder	•	
	Auxiliary hydraulic valve	•			Full-automatic air conditioner	•	
	Combined flow system & boom priority	•			Pilot cut-off lever	•	
	Boom and arm holding valve	•			Windscreen wiper	•	
	Multi-stage filtering system	•			Openable roof-top and left windows, turn-over front wind shield	•	
	1st Auxiliary hydraulic circuit line to arm end (2 pipes)	•			Rearview mirror	•	
	2nd Auxiliary hydraulic circuit line to arm end (2 pipes)	•			Cigar lighter	•	
	3rd hydraulic quick hitch line to arm end (2 pipes)	•			Sunshade curtain	•	
	Oil return pipe (1 pipe)	•			Beacon light	•	
	Hydraulic quick coupler hose	•			Travel alarm	•	
	Hydraulic quick coupler		•		Rear camera	•	
ELECTRONIC/ELECTRICAL CONTROL SYSTEM	ELAC system	•			Cab headlight	•	
	Self-diagnosable system	•		Cab back light	•		
	Automatic idling system	•		ATTACHMENTS	Quick coupler		•
	Adjustable LCD color monitor	•			One bucket as standard	•	
	Restarting-prevention circuit for engine	•			17.72 inch bucket		•
	Battery (2×12 V/120 Ah)	•			35.43 inch bucket		•
	Advanced mode control system	•			44.09 inch bucket		•
	Engine speed sensor-based power control system	•			82.68 inch bucket		•
	Safe shutdown/startup function	•		BOOM	224.41 inch boom	•	
	Battery cut-off switch	•			Boom safety valve	•	
	2× High-performance LED work lights on both sides of the boom	•		ARM	114.96 inch arm	•	
	1× High-performance LED work light on right side of cab	•			Arm safety valve	•	
	Starting motor (24 V/7.7 kW)	•		TRACK	Steel tracks 23.62 inch	•	
	Auto-lubrication system		•		Steel tracks 27.56 inch		•
	Electric refuelling pump		•		Steel tracks 34.5 inch		•
	Smart fleet system		•		Rubber pads for steel tracks		•
				OTHERS	Hand rail	•	

TECHNICAL PARAMETERS

		Imperial	Metric	
TYPE OF CAB		Cab	Cab	
BUCKET CAPACITY		4,8819-6,7126 in ³	0.8-1.1 m ³	
BUCKET WIDTH, STD.		1'3"	370 mm	
MACHINE WEIGHT		4,8061 - 4,9163 lb	21800 - 22 300 kg	
DIMENSIONS	Overall dimension (L × W × H)	31'5" × 9'10" × 10'4"	9 570 × 2 990 × 3 150 mm	
	A Total length	31'5"	9 570 mm	
	B Total height	10'4"	3 150 mm	
	C Total with	9'10"	2 990 mm	
	D Ground clearance of counter weight	3'6"	1 070 mm	
	E Minimum ground clearance	17"	480 mm	
	F Tail swing radius	9'	2 750 mm	
	G Track length on the ground	11'12"	3 653 mm	
	H Track length	14'8"	4 459 mm	
	I Track gauge	7'10"	2 390 mm	
	J Undercarriage width	9'10"	2 990 mm	
	K Track shoe width	1'12"	600 mm	
	L Cab height	9'10"	2 990 mm	
	M Height of engine hood	8'3"	2 520 mm	
	N Width of turntable	8'11"	2 710 mm	
		Boom length	18'8"	5 700 mm
		Arm length	9'7"	2 920 mm
ENGINE	Brand	CUMMINS	CUMMINS	
	Model	QSB6.7	QSB6.7	
	Type	High pressure common rail	High pressure common rail	
	Emission rating	Tier 4 Final	Tier 4 Final	
	Displacement	1.77gal	6.7 L	
	Output	175.39hp/ 2,200 rpm	129 kW / 2 200 rpm	
	Max torque	881 N*m / 1,300 rpm	881 N*m / 1300 rpm	
TRACK	Type	Steel track	Steel track	
	Rubber shoe width	1'12"	600 mm	
UNDERCARRIAGE	Track length	14'8"	4 459 mm	
	Traveling speed (High/Low)	3.2/2.1mi/h	5.2/3.3 km/h	
	Gradeability	35 deg	35 deg	
SWING SPEED		11.8 rpm	11.8 rpm	
GROUND PRESSURE		47 kpa	47 kpa	
HYDRAULIC PUMPS	Hydraulic pump type	2×Variable piston pump	2×Variable piston pump	
	Max displacement of hydraulic pump	2×68.68 gal/min	2×260 L/min	
	Hydraulic pressure of hydraulic pump	31.4/34.3 Mpa	31.4/34.3 Mpa	
	Pilot pump	1×Gear pump	1×Gear pump	
	Max displacement of pilot pump	5.28 gal/min	20 L/min	
	Hydraulic pressure of pilot pump	3.9 Mpa	3.9 Mpa	
SWING MOTOR		Piston motor	Piston motor	
TRAVEL MOTOR		Piston motor	Piston motor	
FUEL TANK CAPACITY		105.66 gal	400 L	
HYDRAULIC OIL TANK CAPACITY		79.25 gal	300 L	

DIMENSIONS

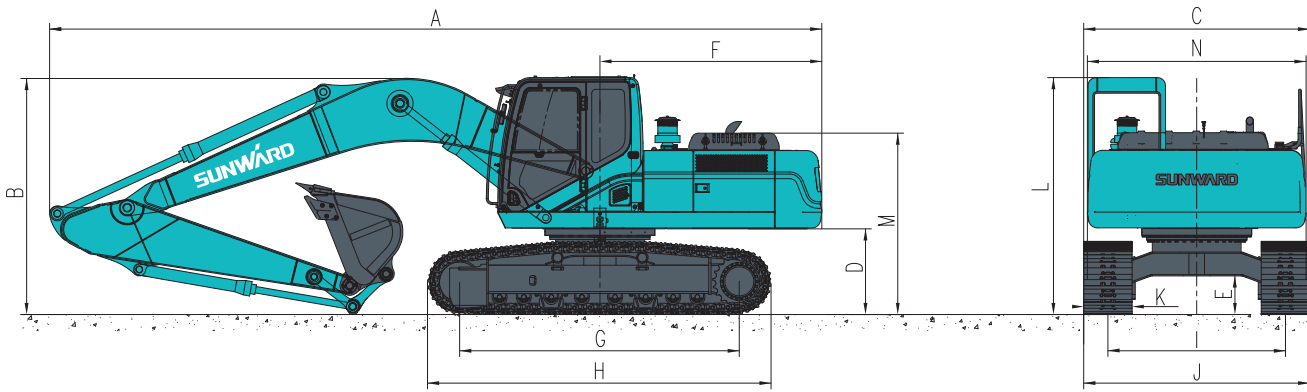

WORKING RANGE

		Imperial	Metric
a	Max. cutting height	31'12"	9 750 mm
b	Max. loading height	22'11"	6 980 mm
c	Max. digging depth	22'2"	6 750 mm
d	Max. digging depth (2.4 m)	21'2"	6 440 mm
e	Max. vertical digging depth	19'4"	5 900 mm
f	Max. digging reach	32'9"	9 980 mm
g	Max. reach on ground	32'3"	9 820 mm
h	Min. front swing radius	11'8"	3 560 mm
g	Max digging force (Bucket)	34,845.4 lbf	155 kN
h	Max digging force (Arm)	24,729 lbf	110 kN

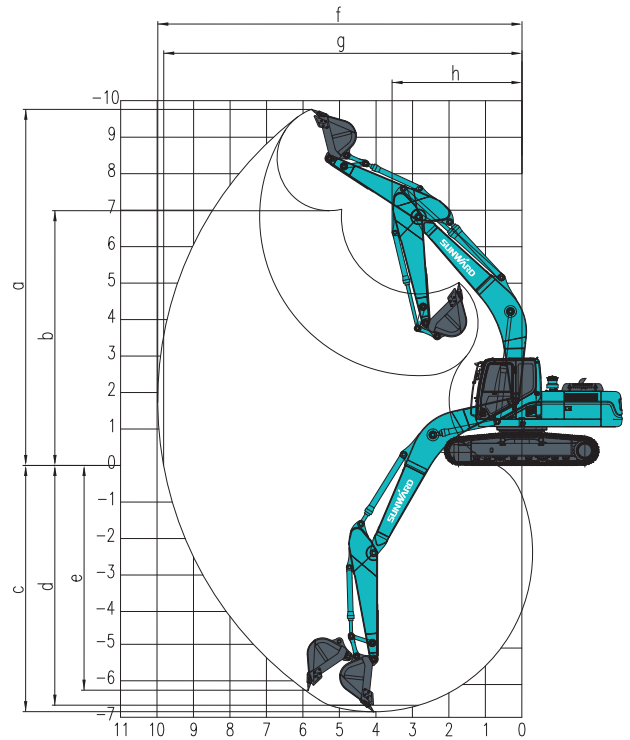

Note:

- The value with * symbol is the rated lifting capacity (calculated in accordance with 87% of the test data)
The value without * symbol is the anti-tipping capacity (calculated in accordance with 75% of the test data)
- A: the distance from swing center to the vertical line of heavy object
B: the distance from bucket mounting pin and horizontal plane

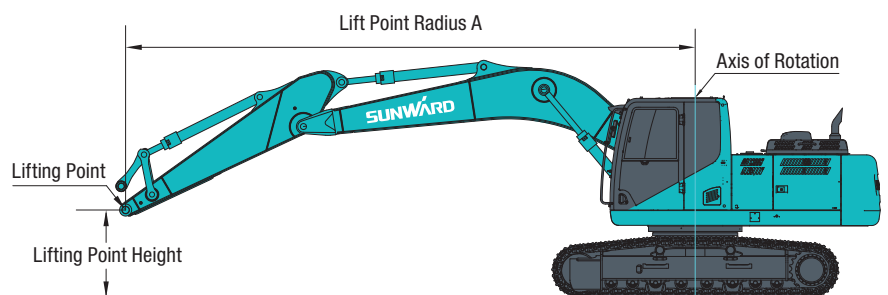

Sunward America and Sunward Canada

Please check our website for our current list of dealers.



SUNWARD AMERICA CORP

✉ 2710 Geesling Road
Denton, TX 76208

☎ (469) 353-6890

✉ Contact@sunwardamerica.com

🌐 www.sunwardamerica.com

DEALER CONTACTS